



**BERGEON**

Maison fondée en 1791

BERGEON & Cie SA  
Outils et fournitures

11, Av. du Technicum  
2400 Le Locle Suisse



Boutons d'oreilles  
Ohrknöpfe  
Ear studs  
Botones para las orejas

Nos boutons d'oreilles et agrafes sont fabriqués avec le plus grand soin, en particulier pour les revêtements d'or et de palladium, des matériaux certifiés ne provoquant pas d'allergies. **Nos boucles sont conformes aux normes suisses et CEE en matière de Nickel.**

Toutes les cartes de boutons sont **stérilisées**. Il est conseillé de porter les boutons 6 semaines c.à.d. jusqu'à cicatrisation complète.

Appareils pour poser les boutons voir planche No 9057 E.

Unsere Ohrknöpfe und Spangen werden mit grösster Sorgfalt hergestellt, insbesondere die Gold- und Palladiumüberzüge, geprüfte Materialien, welche keine Allergien hervorrufen. **Der Nickelgehalt unserer Knöpfe entspricht den schweizer Normen und der EU.**

Alle Ohrknopfarten sind **sterilisiert**. Es ist zu empfehlen die Knöpfe 6 Wochen zu tragen, d.h. bis zur vollständigen Vernarbung.

Gerät zum Aufsetzen der Knöpfe, siehe Tafel Nr. 9057 E.

Our ear-studs and clips are manufactured with extreme care, specially gold and palladium plating, both guaranteed materials that do not cause any allergy. **Our ear-studs and clasps are in accordance with Swiss and CEE standards regarding the nickel.**

All our ear-studs cards are **sterilized**. It is advised to wear the ear-studs for 6 weeks until complete cicatrization.

Ear piercing instruments: please refer to page No 9057 E.

Nuestros pendientes y cierres están fabricados con gran esmero, particularmente para los de revestimiento de oro y de paladium, son materiales certificados que no provocan alérgias. **Nuestros pendientes son conformes a los normas Suizas y CEE en respecto al níquel.**

Todas las cartas de pendientes están **esterilizadas**. Se aconseja de poner los pendientes 6 semanas, es decir hasta cicatrización completa.

Aparatos para poner los pendientes, véase página No 9057 E.



Toutes nos cartes se composent de 12 paires de boutons d'oreilles. Pour certains assortiments vous trouverez également des cartes de **6 paires**.

Alle unsere Karten setzen sich aus 12 Paar Ohrknöpfen zusammen. Für einige Sätze finden Sie ebenfalls Karten mit **6 Paar**.

All our cards are presented with 12 pairs of ear-studs. Some assortments are also presented in **6 pairs'** cards execution.

Todas nuestras cartas se componen de 12 pares de pendientes. Para ciertos surtidos, encontrarán igualmente cartas de **6 pares**.

CLASSIQUE

MINI

BABY

DE LUXE









NICKEL-FREE  
STUDS AND CLIPS









Boutons "fantaisie"  
"Phantasie" Ohrknöpfe  
"Fancy" studs  
Botones "fantasía"



| GENRE - ART - STYLE - GENERO |  | Gris palladium - Palladiumgrau<br>Palladium grey- Gris paladium |         | Doré jaune - Gelb vergoldet<br>Gilt - Dorado amarillo |         |
|------------------------------|--|---|---------|---|---------|
| Ø 3,95                       | <b>CLASSIQUE</b>   | No  | Pce Fr. | No  | Pce Fr. |
|                              |   Boule<br>Kugel<br>Ball<br>Bola | No 5991-NF-D  |         | No 5991-NF-F  |         |

| PIERRE - STEIN - STONES - PIEDRA  |  |               |  |               |  |
|---|--|---------------|--|---------------|--|
|   | Aigue-marine<br>Aquamarin<br>Aquamarine<br>Aguamarina      | No 6135-NF-03 |  | No 6136-NF-03 |  |
|    | Diamant<br>Diamant<br>Diamond<br>Diamante                  | No 6135-NF-04 |  | No 6136-NF-04 |  |
|    | Emeraude<br>Smaragd<br>Emerald<br>Esmeralda                | No 6135-NF-05 |  | No 6136-NF-05 |  |
|    | Rubis<br>Rubin<br>Ruby<br>Rubi                             | No 6135-NF-07 |  | No 6136-NF-07 |  |
|    | Saphir<br>Saphir<br>Sapphire<br>Zafiro                     | No 6135-NF-09 |  | No 6136-NF-09 |  |
|    | Zircon rose<br>Rosa Zirkon<br>Rose Zircon<br>Circón rosado | No 6135-NF-10 |  | No 6136-NF-10 |  |
| Ass. de couleurs différentes<br>Satz von verschiedenen Farben<br>Assortment of different colours<br>Surtido de colores diferentes | 2 x 6  | No 6137-12-NF |  | No 6138-12-NF |  |
|   | 1 x 6  | No 6137-06-NF |  | No 6138-06-NF |  |

| FORME - FORM - SHAPE - FORMA  |   |                                     |               |               |               |
|---|---|-------------------------------------|---------------|---------------|---------------|
|    |  | Etoile<br>Stern<br>Star<br>Estrella | No 6135-NF-31 |               | No 6136-NF-31 |
|    |  | Coeur<br>Herz<br>Heart<br>Corazón   | No 6135-NF-32 |               | No 6136-NF-32 |
|    |  | Lune<br>Mond<br>Moon<br>Luna        | No 6135-NF-36 |               | No 6136-NF-36 |
| Ass. de formes différentes<br>Satz von verschiedenen Formen<br>Assortment of different shapes<br>Surtido de formas diferentes | 4 x 3   | No 6335-12-NF                       |               | No 6336-12-NF |               |
|   | 2 x 3   | No 6335-06-NF                       |               | No 6336-06-NF |               |



BERGEON & Cie SA  
Outils et fournitures

**BERGEON**

Maison fondée en 1791

11, Av. du Technicum  
2400 Le Locle Suisse



Spécialement pour le 2ème et le 3ème bouton  
Besonders für den 2 und 3 Ohrlochknopf  
Especially for 2 and 3 stud  
Especialmente para el 2 y 3 botón



NICKEL FREE  
STUDS AND CLIPS

| GENRE - ART - STYLE - GENERO  |      |       | Gris palladium - Palladiumgrau<br>Palladium grey- Gris paladium |               | Doré jaune - Gelb vergoldet<br>Gilt - Dorado amarillo |               |  |
|---|------|-------|---|---------------|---|---------------|--|
| Ø 2.48  | MINI |       | No  | Pce Fr.       | No  | Pce Fr.       |  |
|   |      |       | Boule<br>Kugel<br>Ball<br>Bola                                  | No 6490-NF-D  |   | No 6489-NF-F  |  |
|   |      |       | Diamant<br>Diamant<br>Diamond<br>Diamante                       | No 6490-NF-01 |   | No 6489-NF-01 |  |
|   |      |       | Rubis<br>Rubin<br>Ruby<br>Rubi                                  | No 6490-NF-02 |   | No 6489-NF-02 |  |
|   |      |       | Saphir<br>Saphir<br>Sapphire<br>Záfiro                          | No 6490-NF-03 |   | No 6489-NF-03 |  |
| Ass. de couleurs différentes<br>Satz von verschiedenen Farben<br>Assortment of different colours<br>Surtido de colores diferentes |      | 4 x 3 | No 6490-12-NF   |               | No 6489-12-NF   |               |  |
|   |      | 2 x 3 | No 6490-06-NF   |               | No 6489-06-NF   |               |  |



Boutons tige courte  
Ohrknöpfe und Klammern, kurzer Stift  
Studs Short stem  
Botones tija corta



NICKEL FREE  
STUDS AND CLIPS

| GENRE - ART - STYLE - GENERO  |   |       | Gris palladium - Palladiumgrau<br>Palladium grey- Gris paladium |   | Doré jaune - Gelb vergoldet<br>Gilt - Dorado amarillo |         |               |
|---|---|-------|---|---|---|---------|---------------|
|   | BABY  |       | No  | Pce Fr.                                   | No  | Pce Fr. |               |
|   | Tête classique<br>Klassischkopf<br>Classic head<br>Cabeza clásico<br>Ø 3.95 |       |   | Boule<br>Kugel<br>Ball<br>Bola            | No 6790-BB-D  |         | No 6791-BB-F  |
|   |   |       |   | Diamant<br>Diamant<br>Diamond<br>Diamante | No 6790-BB-04   |         | No 6791-BB-04 |
|   | Tête mini<br>Minikopf<br>Mini head<br>Cabeza mini<br>Ø 2.48                 |       |   | Boule<br>Kugel<br>Ball<br>Bola            | No 6792-BB-D  |         | No 6793-BB-F  |
|   |   |       |   | Diamant<br>Diamant<br>Diamond<br>Diamante | No 6792-BB-01   |         | No 6793-BB-01 |
| Ass. de chaque genre<br>Satz von jeder Art.<br>Assortment of each Style<br>Surtido de cada genero |   | 3 x 4 | No 6794   |   | No 6795   |         |               |

A poser avec l'appareil  
Zu benutzen mit Gerät  
Use with the instrument  
A poner con el aparato

**6600-BB**

ou l'appareil  
oder mit Gerät  
or with the instrument  
o con el aparato

**6600 +**

le set  
dem Satz  
the set  
el surtido

**6600-S**





NICKEL  
FREE  
STUDS AND CLIPS



*De Luxe*



Boutons à griffes  
Ohrknöpfe mit Krallen  
Studs with prongs  
Botones con garras



| GENRE - ART - STYLE - GENERO |   | Gris palladium - Palladiumgrau<br>Palladium grey- Gris paladium |                 | Doré jaune - Gelb vergoldet<br>Gilt - Dorado amarillo |               |  |
|------------------------------|---|---|-----------------|---|---------------|--|
| Ø 3.95                       | DE LUXE   | No  | Pce Fr.         | No  | Pce Fr.       |  |
|                              |    | Diamant<br>Diamant<br>Diamond<br>Diamante                       | No 6539-NF-D-01 |   | No 6539-NF-01 |  |
|                              |    | Rubis<br>Rubin<br>Ruby<br>Rubi                                  | No 6539-NF-D-02 |   | No 6539-NF-02 |  |
|                              |    | Saphir<br>Saphir<br>Sapphire<br>Záfiro                          | No 6539-NF-D-03 |   | No 6539-NF-03 |  |
|                              | Ass. de couleurs différentes<br>Satz von verschiedenen Farben<br>Assortment of different colours<br>Surtido de colores diferentes | 4 x 3   | No 6540-12-NF-D |   | No 6540-12-NF |  |
|                              | 2 x 3   | No 6540-06-NF-D   |                 | No 6540-06-NF   |               |  |

Conforme aux normes Suisse et  Gemäss schweizer und EU- Normen In conformity with Swiss and  standards Conforme a las normas Suizas + 



**BERGEON**

Maison fondée en 1791

BERGEON & Cie SA  
Outils et fournitures

11, Av. du Technicum  
2400 Le Locle Suisse

**Appareils à percer les oreilles sans douleurs**

**Apparate zum schmerzlosen Ohrlochstechen**

**Ear piercing instruments, without pain**

**Aparatos para perforar sin dolor el lóbulo de las orejas**

**CLASSIQUE  
MINI  
DE LUXE**

No 6600



**CLASSIQUE  
MINI  
BABY  
DE LUXE**

No 6600-BB



**BABY**

No 6600-S

Set BABY pour l'appareil No 6600  
Satz BABY für den Apparat Nr 6600  
Set BABY for instrument No 6600  
Juego BABY para el aparato No 6600



| Article<br>Artikel<br>Artículo | No | Porte-bouton CLASSIQUE<br>CLASSIQUE-Knopfhalter<br>CLASSIQUE stud holder<br>Porta botón CLASSIQUE | Porte-bouton MINI<br>MINI-Knopfhalter<br>MINI stud holder<br>Porta botón MINI | Extracteur<br>Auswerfer<br>Extractor<br>No 6600-H | Porte-bouton BABY classique<br>BABY classique-Knopfhalter<br>BABY classique stud holder<br>Porta botón BABY classique<br>No 6600-BB-F | Porte-bouton BABY MINI<br>BABY MINI-Knopfhalter<br>BABY MINI stud holder<br>Porta botón BABY MINI<br>No 6600-BB-G | Entretoise<br>Zwischenstück<br>Intermediate piece<br>Apoyo<br>No 6600-ENT | Stylo médical<br>Medizinalstift<br>Medical pen<br>Lapicero médico<br>No 5990-D |
|--------------------------------|----|---|---|---|---|---|---|--|
| 6600                           | X  | X   | X   | X   |   |   |   | X  |
| 6600-BB                        | X  | X   | X   | X   | X   | X   | X   | X  |
| 6600-S                         |    |   |   |   | X   | X   | X   |  |

|         |         |         |
|---------|---------|---------|
| No 6600 | 295 gr. | Pce Fr. |
|---------|---------|---------|

|            |         |         |
|------------|---------|---------|
| No 6600-BB | 300 gr. | Pce Fr. |
|------------|---------|---------|

|           |       |         |
|-----------|-------|---------|
| No 6600-S | 2 gr. | Pce Fr. |
|-----------|-------|---------|

**Désinfectant**

Pour désinfecter les lobes d'oreilles.

**Desinfiziermittel**

Zum Desinfizieren der Ohrflächchen.

**Desinfectant**

To desinfect ears' lobes.

**Desinfectante**

Para desinfectar el lóbulo de las orejas.



No 6140



No 6140-12



No 6427

|   | No      | gr. | Pce Fr. |
|---|---------|-----|---------|
| 1 Flaçon<br>1 Flasche<br>1 Bottle<br>1 Frasco         | 6140    | 24  |         |
| 12 Flaçons<br>12 Flaschen<br>12 Bottles<br>12 Frascos | 6140-12 | 305 |         |
| 50 Tampons<br>50 Tupfer<br>50 Pads<br>50 Gasas        | 6427    | 160 |         |



**Mode d'emploi pour l'appareil à percer les oreilles**

**Gebrauchsanweisung für den Ohrlochstecher**

**Instructions for use for the ear piercing instrument**

**Modo de empleo para aparato para perforar el lóbulo de las orejas**

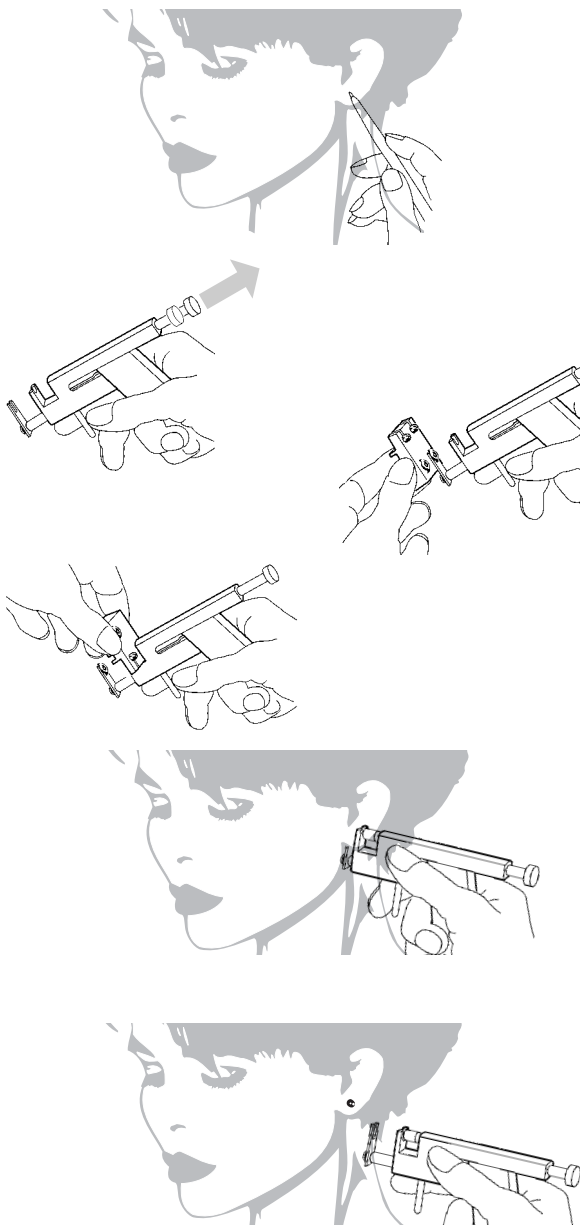
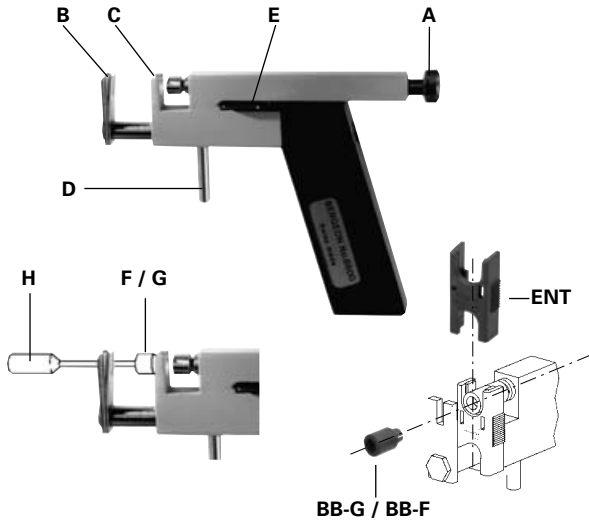

- 1** Désinfecter les lobes d'oreilles avec le désinfectant No 6140 ou avec un tampon antiseptique No 6427 ou avec de l'alcool à 70° et marquer les endroits à percer avec le stylo médical No 5990-D.  
Die Ohr läppchen mit dem Desinfiziermittel No 6140 oder mit dem antiseptischen Tupfer Nr 6427 oder mit Alkohol zu 70° desinfizieren und Stechstelle mit dem Medizinalstift Nr 5990-D markieren.  
Desinfect ear lobes with either desinfectant No 6140 or antiseptic pads No 6427 or with alcohol at 70° and then mark the relevant place with the medical pen No 5990-D.  
Desinfectar el lóbulo de las orejas con el desinfectante No 6140 o con gasa antiséptica No 6247 o con alcohol a 70° y marcar los sitios para perforar con el lapizero medical No 5990-D.
- 2** Armer l'appareil en tirant sur le piston A.  
Die Feder des Apparates spannen, indem man an dem Zapfen A zieht.  
Wind up the instrument by pulling the piston A.  
Armar el muelle del aparato, tirando del pistón A.
- 3** Sortir l'agrafe stérilisée de son support en plastique en glissant celle-ci dans le logement B de l'appareil, sans toucher l'agrafe avec les doigts.  
Die sterilisierte Klammer aus ihrem Plastikhalter nehmen und diese in den Platz B des Apparates einschieben, aber ohne die Klammer mit den Fingern zu berühren.  
Take the clasp out of its plastic support by sliding this clasp into the part B of the instrument. Do not touch the clasp with your fingers.  
Sacar el broche esterilizado de su base plástica y colocarlo en la hendidura B del aparato, sin tocar el broche con los dedos.
- 4** Introduire la tête du bouton dans le porte-bouton C sans le toucher avec les doigts. Tirer l'emballage vers le haut.  
Den Kopf des Knopfes in den Knopfhalter C einführen, ohne ihn mit den Fingern zu berühren. Die Verpackung nach oben ziehen.  
Insert the stud head into the stud holder C. No fingers on it !. Lift the packing up.  
Introducir la cabeza del botón en el soporte C sin tocar con los dedos. Tirar la envoltura hacia arriba.
- 5** Placer le lobe de l'oreille dans l'appareil. Viser le point fait précédemment, avec la pointe du bouton. Serrer complètement le lobe contre l'appareil au moyen du levier D. Das Ohr läppchen in den Apparat schieben. Den blauen Punkt mit der Spitze des Knopfes gegenüber stellen. Das Ohr läppchen mit dem Hebel D ganz gegen den Apparat drücken. Adjust the ear's lobe in the instrument. Take aim at the previously marked place with the stud's tip. Lock up ear's lobe in the instrument with the sear D.  
Colocar el lóbulo de la oreja en el aparato. Apuntar la marca azul con la punta del botón. Apretar el lóbulo completamente enfrente al aparato mediante la varilla D.
- 6** Déclencher l'appareil en appuyant de manière résolue avec le pouce sur le levier E. Dès cet instant l'oreille est percée et l'agrafe et le bouton sont en place.  
Den Apparat auslösen, indem man mit dem Daumen fest auf den Hebel E drückt. Sofort ist das Ohr läppchen durchstochen und die Klammer sowie der Knopf sind eingeschoben.  
Release the instrument by pushing firmly with your thumb on the lever E. The ear is now pierced with both stud and clasp in the right position.  
Disparar el aparato apoyando con el pulgar sobre la palanca E. Desde este instante el lóbulo es perforado y tanto el broche como el botón quedan en su sitio.
- 7** Relacher le levier D et dégager l'appareil en le déplaçant vers le bas.  
Den Hebel D loslassen und den Apparat entfernen.  
Loosen the sear D and remove the instrument down.  
Soltar la palanca D y retirar el aparato hacia abajo.